

Mains Operated Sensor Tap

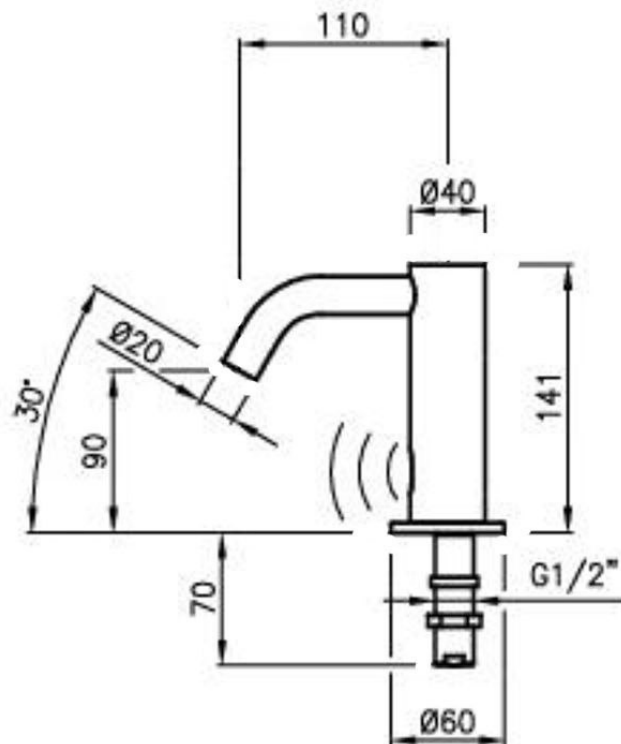

Product Code: MST

This mains operated sensor tap has a forward facing sensor window so users can see where the tap is triggered. Easy to use this tap helps prevent the spread of germs associated with multiple users touching surfaces.

Delivery

From stock typically 1 to 2 working days

Tech Spec

Sensor operated hand wash tap
No touch operation for safe and hygienic hand washing
Chrome plated brass body
Downward angled spout to allow less water retention
Forward facing sensor window
3 second turn off when hands removed
13 second safety shut off - sensor needs to be re-triggered after 13 seconds of continuous use to prevent water waste
Single inlet for cold or pre-mixed water
WRAS approved
1 year manufacturers warranty against defects
35mm tap hole required
Supplied with solenoid valve and mains transformer
Inline Y strainer or filter should be used to protect the solenoid from water borne debris

Specification

Minimum pressure required 0.5 Bar
Max water pressure 6 Bar
Max temperature 80 degrees C
Standard closing time 3 seconds
Spout height 90mm
Spout reach 110mm

Related Products

Battery operated sensor tap

**All pictures shown are for illustration purpose only and may be subject to change without notice. Actual product may vary due to product enhancement.
All dimensions shown are for guidance only and may be subject to change or alteration without notice. All items manufactured or purchased separately from a third party to fit our products should be checked against the actual dimensions of the physical product before purchase. We will not be liable for third party costs and consequential loss associated with the items not fitting third party components.**