

Infra Red Sensor Tap

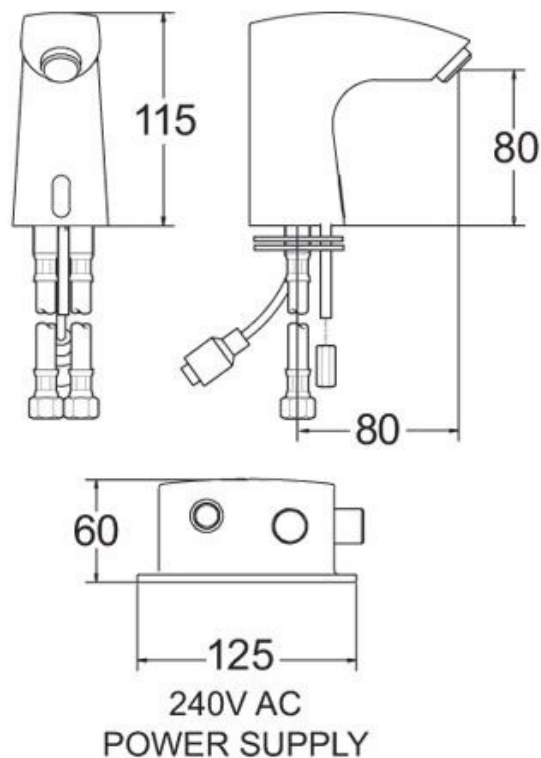

Product Code: S1D

Infra-red sensor operated basin tap. This tap has a modern spout design and is manufactured from chrome plated brass.

When the user's hands enter the washing area water will dispense, water will stop when the user's hands are removed from the sensor area.

Supplied with a mains power control box with a battery back up in case of power failure, the tap will also work solely from battery power if required.

Delivery

Typically 1 to 2 working days

Tech Spec

Scratch resistant sensor window
Single inlet for cold or pre-mixed water
Moisture and water resistant control unit
WRAS approved
2 years' manufacturer's warranty against defects
30mm tap hole required

Water Pressure

Minimum pressure required 0.5 Bar

Related Products

We recommend the use of a [TMV3 thermostatic mixing valve](#) on all taps providing premixed or hot water.

**All pictures shown are for illustration purpose only and may be subject to change without notice. Actual product may vary due to product enhancement.
All dimensions shown are for guidance only and may be subject to change or alteration without notice. All items manufactured or purchased separately from a third party to fit our products should be checked against the actual dimensions of the physical product before purchase. We will not be liable for third party costs and consequential loss associated with the items not fitting third party components.**