

## Drinking Water Fountain

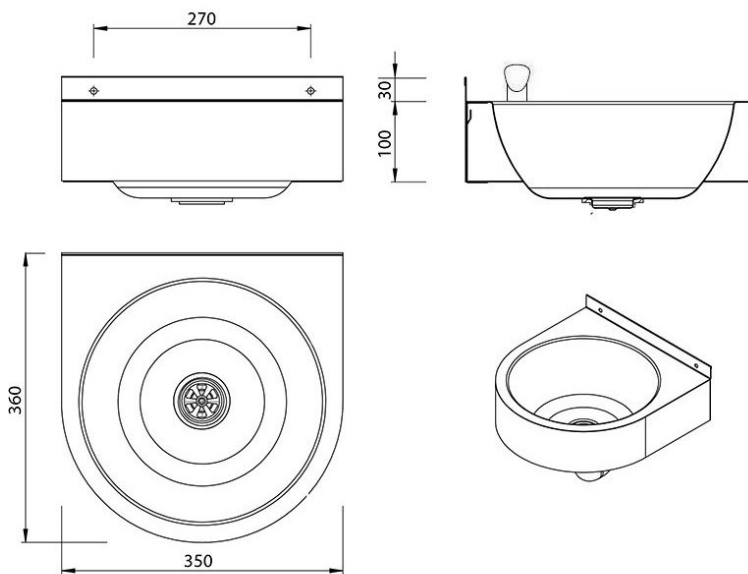

Product Code: DWF

This drinking fountain is manufactured with a rounded front to make it more comfortable and safe for users and a deep bowl to help prevent splashing.

Supplied with a WRAS approved bubbler tap, 32mm waste fitting and concealed wall bracket, you can also specify a trap so that your installer has everything in the box ready to install.

### Delivery

From stock typically 1 to 2 working days

### Tech Specs

Width: 350mm  
Front to back: 360mm  
Height: 100mm high plus 30mm rear upstand  
Grade 304 stainless steel  
Rounded front for safety.  
Hidden wall bracket  
32mm flush grated waste fitting  
Please note the bowl is satin finish the previous version had a bright polished bowl

### Related Products

Bottle filling fountain  
32mm plastic bottle trap  
32mm chrome plated brass bottle trap with chrome brass pipe and wall flange

\*\*All pictures shown are for illustration purpose only and may be subject to change without notice. Actual product may vary due to product enhancement.  
All dimensions shown are for guidance only and may be subject to change or alteration without notice. All items manufactured or purchased separately from a third party to fit our products should be checked against the actual dimensions of the physical product before purchase. We will not be liable for third party costs and consequential loss associated with the items not fitting third party components.\*\*