

Vandal Resistant Wall Hung Trough Urinal 1500mm

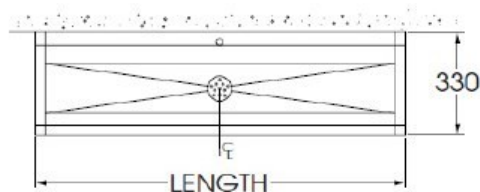

Plan

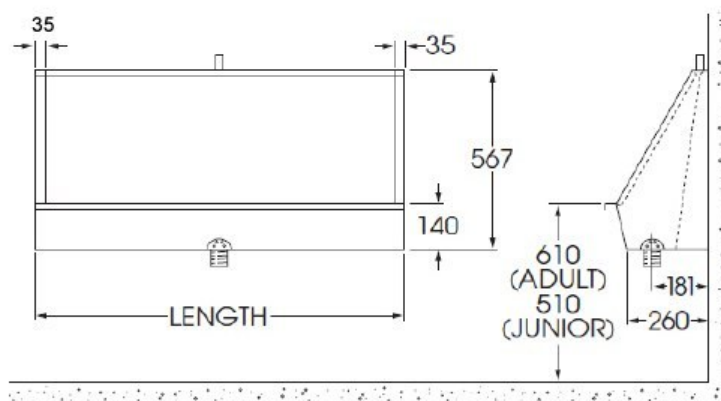

Front Elevation

End Elevation

Product Code: UWHA-1500

Heavy Duty Vandal Resistant Wall Hung Trough Urinal

Product code UWHA-1500

- In stock for 1 to 2 working day delivery at standard delivery prices.
- Manufactured from 1.6mm thick grade 304 stainless steel for maximum vandal resistance and durability.
- Strong, robust and designed to stand up to heavy use.
- 33% thicker than most stainless steel urinals on sale.
- 1500mm long.
- Ends suitable for fitting flush to the side wall or leaving exposed.
- Concealed sparge flushing system to prevent vandalism.
- Large 330mm trough projection from the wall.
- Complete with central 2" BSP waste fitting, exposed plastic auto flushing cistern, stainless steel downpipe and clips.

Delivery

- Standard delivery time 1 to 2 working days (at no extra cost to standard delivery).

Optional Extras

- 2" plastic swivel waste P trap with 75mm water seal.
- Stainless steel auto flushing cistern instead of plastic.
- [Marnic Water Watch flush controller](#).

All pictures shown are for illustration purpose only and may be subject to change without notice. Actual product may vary due to product enhancement. All dimensions shown are for guidance only and may be subject to change or alteration without notice. All items manufactured or purchased separately from a third party to fit our products should be checked against the actual dimensions of the physical product before purchase. We will not be liable for third party costs and consequential loss associated with the items not fitting third party components.